

WATERTIGHT ROOF SLABS

Guidelines and General Principles

AUSTRALIAN PRESTRESSING SERVICES PTY LTD

Mr. Hossein Rahimi

22 August 2007

INTRODUCTION

Definition of a Watertight Slab

In the Standards:

- AS3600
- AS3735
- ACI 318
- BS8110

Definition of a Watertight Slab

➤ In Australian Industry
(Concrete Institute of Australia):

“Being impermeable to water except when under hydrostatic pressure sufficient to produce structural discontinuity by rupture”

How do we achieve a watertight slab?

Concrete mix design:

- Standards, particularly the ACI, advise the W/C ratio be limited to not more than 0.5, and 0.45 for freezing & thawing in a moist conditions.
- Limit flyash and other pozzolan material content.
- Limit 56 day drying shrinkage to 550 microstrain.

How do we achieve a watertight slab?

Admixtures:

- Limited advantages: ACI Committee 212 : “unlikely to produce any appreciable reduction in permeability where the concrete has been well cured and the W/C ratio is not more than 0.6 by weight.”
- Some admixtures may have detrimental effects (eg: derived from soaps, water repellents)

How do we achieve a watertight slab?

Structural design:

- Crack control
 - Flexural
 - Shear
 - Shrinkage
 - Thermal
 - Restraint

How do we achieve a watertight slab?

Structural design:

- It is quite common in the industry that watertight slabs are produced from assuming a *strong* degree of crack control as defined by AS3600.
- This is commonly specified in terms of minimum residual P/A values with supplementary reinforcement (mesh).

How do we achieve a watertight slab?

Early Thermal Cracking

Definition:

- Early thermal cracking is the result of the heat of hydration as the concrete hardens
- BS8110 refers to thermal & plastic cracking and not shrinkage cracking

Prevention of Early Thermal Cracking

- Proper curing techniques.
- Timely initial stressing based on actual concrete strength development
- Early strength concrete, but not in a large pours where cold joints may happen

Prevention of Early Thermal Cracking

- Reinforcement for crack distribution eg. mesh.
- Proper compaction techniques, re-vibration where necessary.

Detailing

- A significant factor in the success of watertight concrete is the handling of restraint issues.
- Cracking of restrained members is a very important factor particularly for PT slabs where there is often no reinforcement to distribute cracking. If restraining actions are not addressed in design and detailing properly, cracks would be fewer, but larger in width.
- Positioning of movement / expansion joints is the primary factor in reducing restraint.

Detailing

- Consider various techniques to isolate stiff / restraining members where feasible.

Detailing

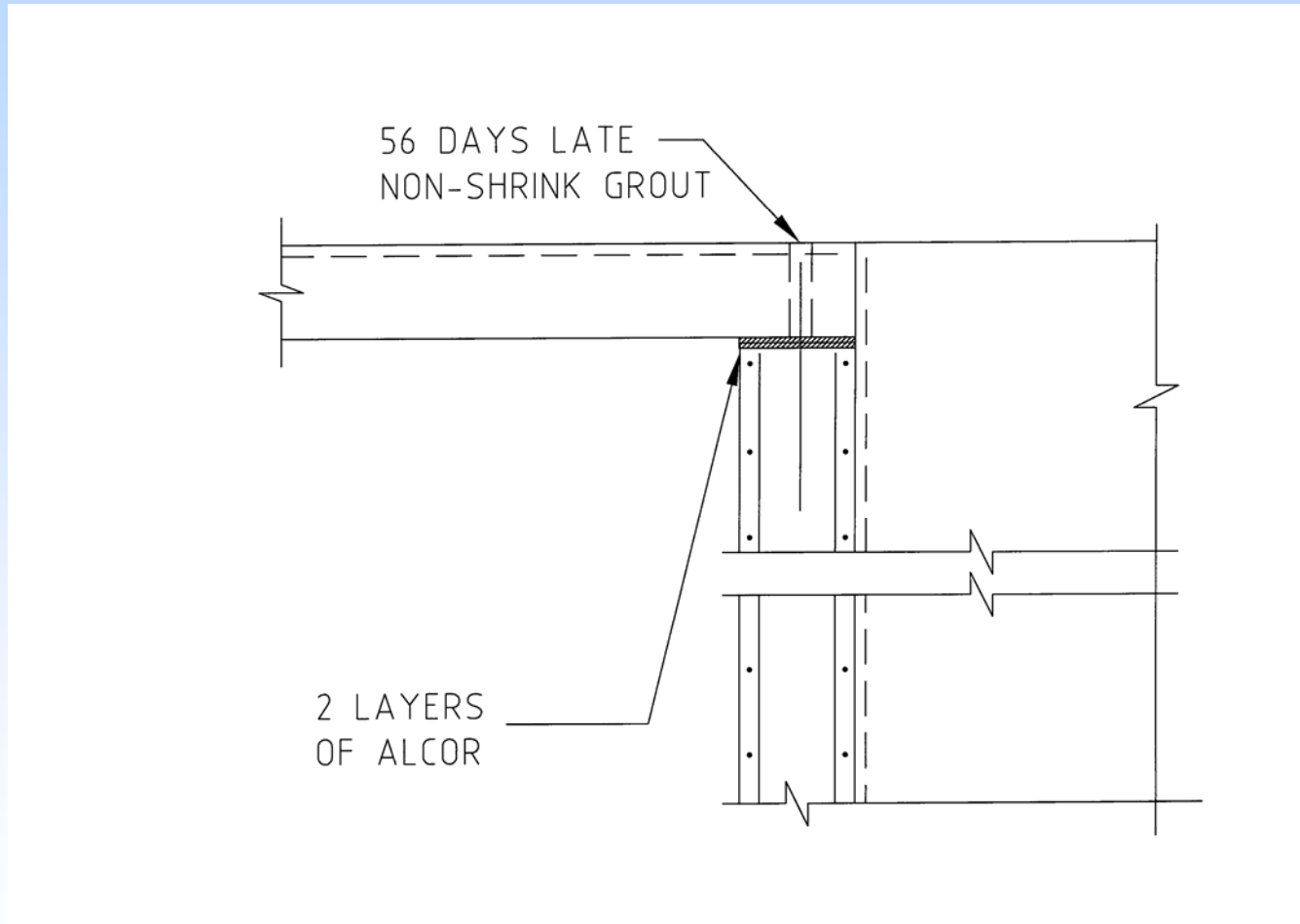

Detailing

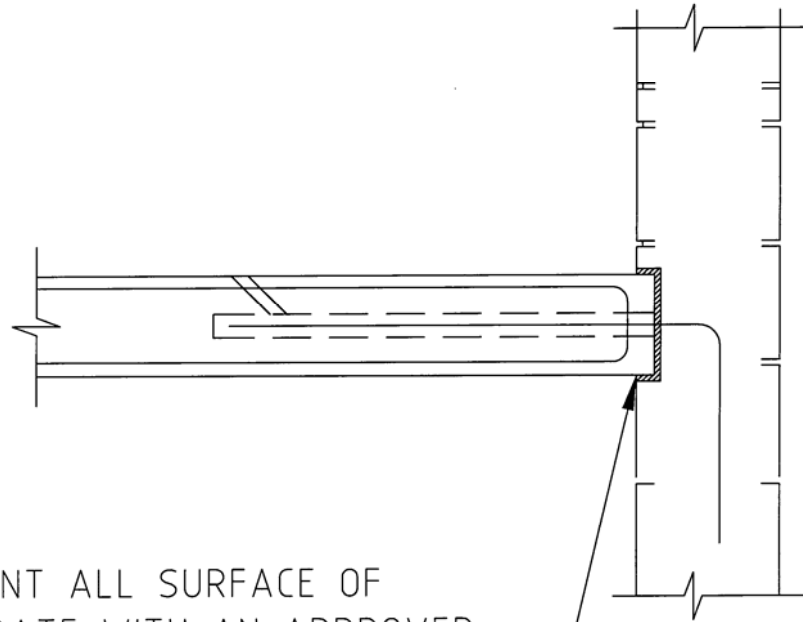

PAIN T ALL SURFACE OF
REBATE WITH AN APPROVED
DE-BONDING AGENT.

Detailing

56 DAYS LATE
IN FILL.

2 LAYER S
OF ALCOR.

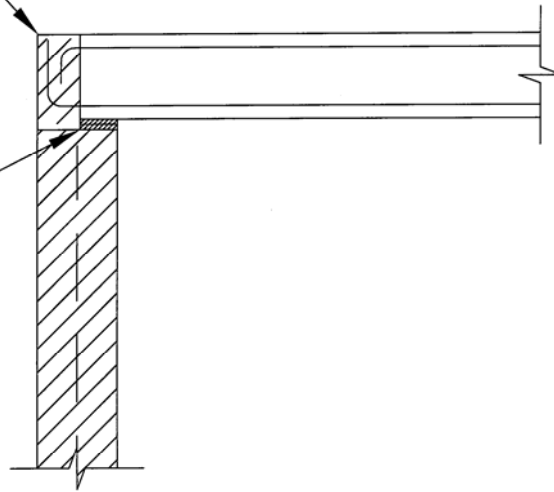

Poor isolation!



Detailing

- Give special consideration to P/A levels & reinforcement in a restrained structure. Large pours particularly with stiff columns and core walls can create significant restraint.

Typical restraint cracking in the secondary direction of a banded slab.



Typical restraint cracking from a large reinforced concrete member



Detailing

➤ Joints

Along with joint location, design of the joint for expected movement levels over the life of the structure is imperative.

Movement joint detail

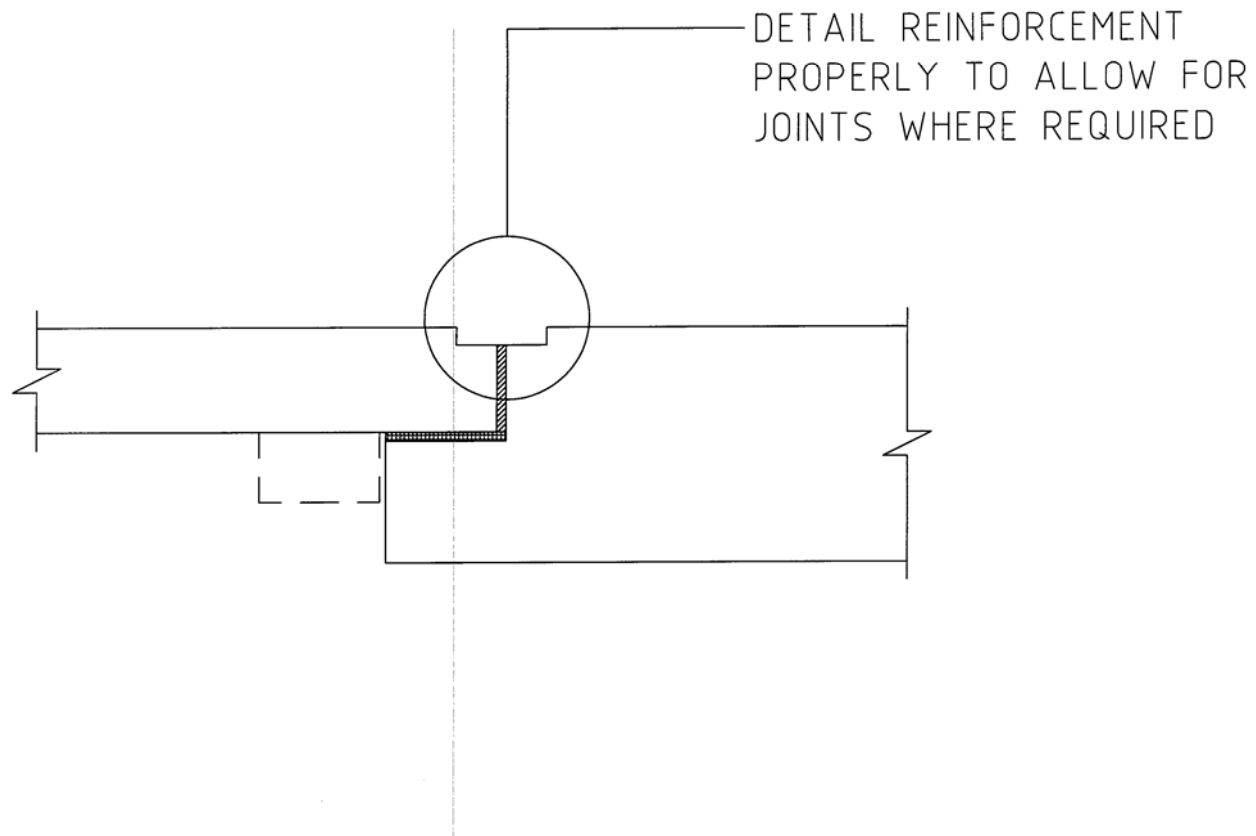

Large pours mean large movement levels at joints



Column cracking



Precast panel restrained at base



Detailing

Splay edge of beams particularly when $D_b > 2D_s$, to reduce / soften transition from beam to slab.

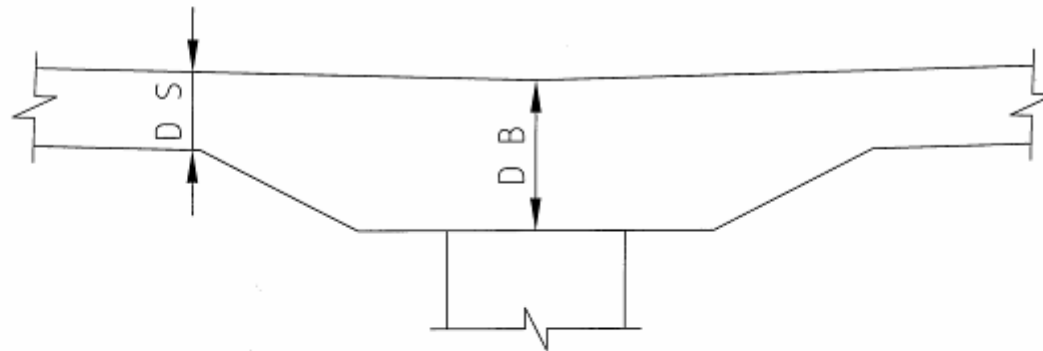

Avoid stressing pans in watertight roofs where possible



Detailing



Formwork:

Smooth surface finish with tight joints to prevent slurry loss, coat with a surface release agent.

CONCLUSION

Watertight roof slabs are the product of team work between the concrete supplier, the engineer, the architect and the construction personnel themselves.